

Article number: 208202355MF

Description: E+G horizontal clamps
GN 820.2-355-MF

Measures

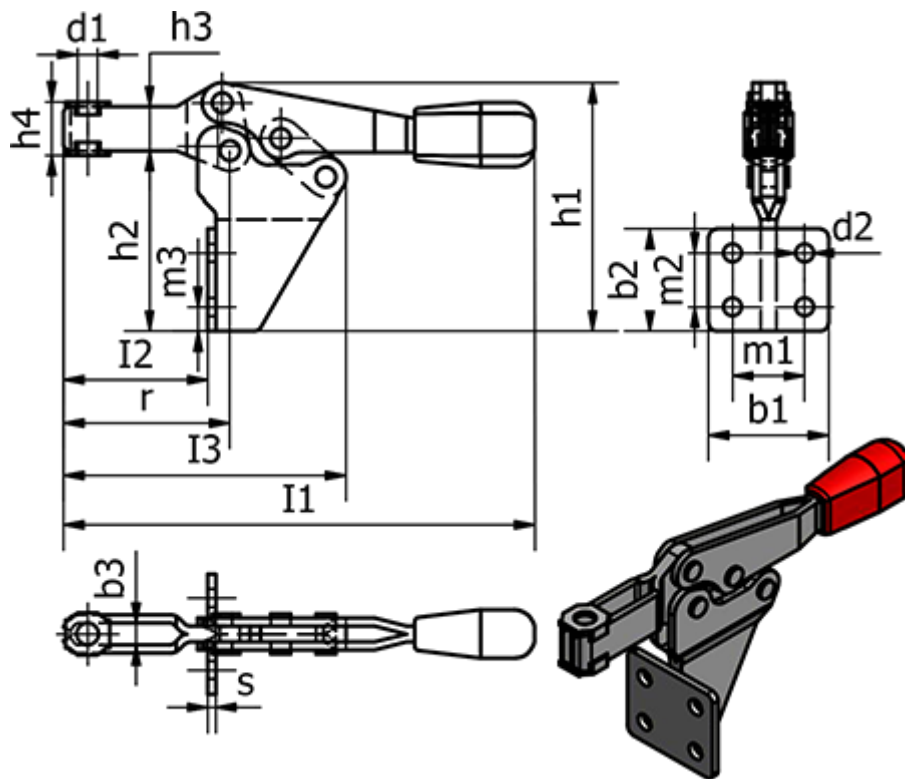

b1 = 52	h4 = 43	r = 108.5
b2 = 52	Holding force in N = 1800	s = 3.5
b3 = 10.5	I1 = 270	Wight (g) = 840
d1 = M10	I2 = 85	
d2 = 8.5	I3 = 166	
h1 = 135	m1 = 32	
h2 = 92	m2 = 32	
h3 = 22	m3 = 10	